

311M

Medium to Heavy Capacity Belt Scale

Specifications

Conveyor Width:

20 in to 50 in

Capacity:

1500 tons/hr

Belt Speed:

400 feet/minute

Inclination:

Maximum 12 degrees

Material:

Powder coated mild steel

System Accuracy:

0.5-1%

Load Cell:

RL1250: 50kg, 100kg, 250kg

Options:

Galvanized or stainless construction

Warranty

One-year limited warranty

Standard Features

- Semi-modular weigh frame design
- Minimum modification to conveyor required
- Weigh frame without moving parts
- Fits standard conveyors - mounts with four bolts
- Requires weigh frame cutting for proper fit

Applications

- Mining, quarries, bulk material blending, process control applications, retrofit applications

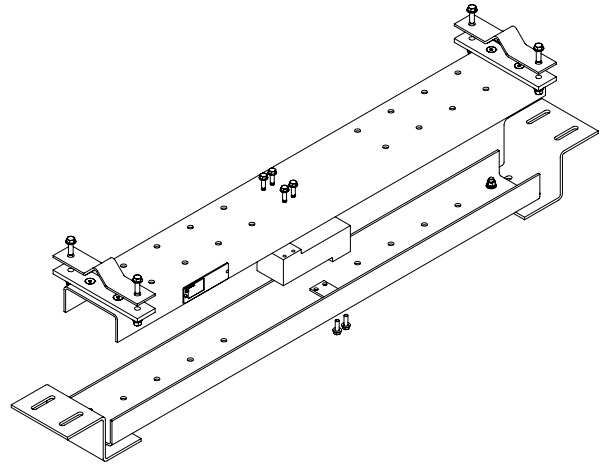

Part Number/Price

PART #	DESCRIPTION	EST. SHIP WEIGHT	PRICE
163296	311M Belt Scale with 50 kg load cell	125 lb	Consult
163297	311M Belt Scale with 100 kg load cell	125 lb	Consult
163298	311M Belt Scale with 250 kg load cell	125 lb	Consult